

SMT NUT & Standoff

- SMT full automatic reflux process can increase product stability and production efficiency
- Welding for reinstallation can increase product reliability

82 SERIES SMT NUT - M2 THREAD Patented.



Material and Finish

Nut :
Carbon Steel, Tin Finish.
Washer :
PTFE.

REEL



■ Panel Preparation

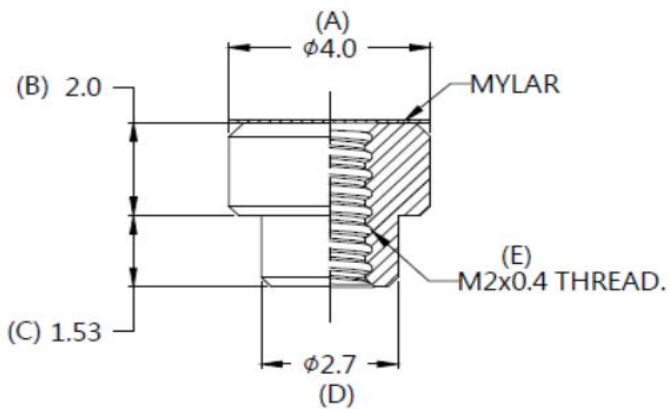

■ Installation

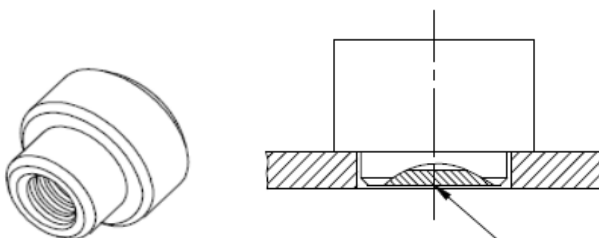
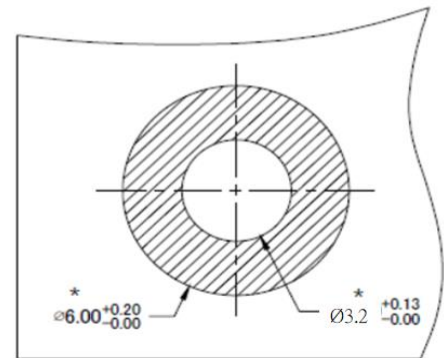
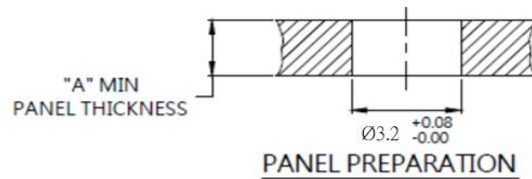

WASHER
(Remove after SMT)

■ Dimensions (mm)

SCREW LENGTH "T"	SCREW PROJECTION		PANEL THICKNESS	
	P-1	P-2	A, MIN	A, MAX
~	~	~	1.6	~